



11636 GOLDRING RD • ARCADIA, CALIFORNIA 91006-5815  
626-358-2559 • FAX 626-359-5701 • 800-525-6925

## INSTRUCTIONS

### TRP-303 Telephone Recorder Patch with Beeps

#### P/N 39270

The TRP-303 provides an analog audio connection to recorders from telephones that have modular connected handsets. It allows clear recording of both sides of your conversation from almost all types of telephones, digital or analog.

The TRP-303 injects a short beep at 15 second intervals onto the phone line. The beep is audible in the earphones of all phones connected to the conversation and is superimposed on a clear recording of both sides of the conversation.

An ON/OFF switch for the beeps is provided on the top of the TRP-303. This switch turns on and off the beeps only. It does not control your recorder or prevent your conversation from being recorded on a running recorder. To adjust the beep volume, insert a small screwdriver through the hole in the bottom of the unit and set the volume control.

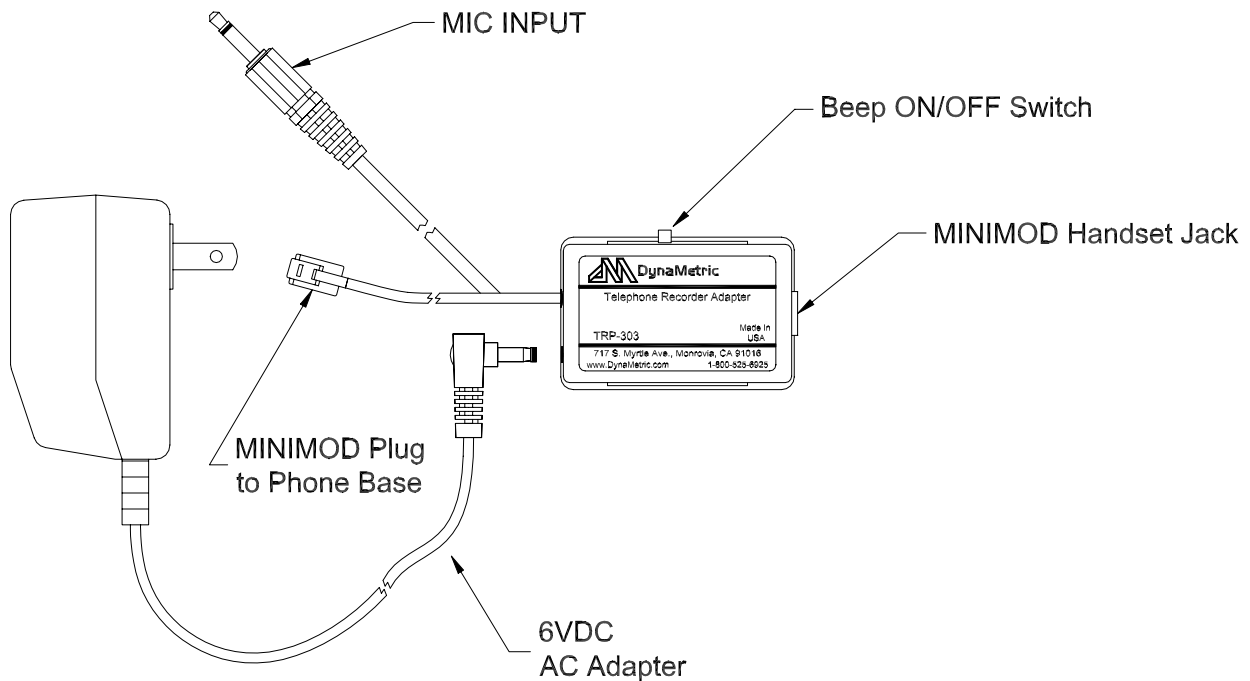

## INSTRUCTIONS

### TRP-303 Telephone Recorder Patch with Beeps

#### To Install: (See diagram)

Disconnect the handset coil cord from the base of the telephone and replace it with the modular plug from the TRP-303. Connect the handset coil cord into the modular receptacle on the TRP-303. Insert the 3.5mm plug (on long cord) into the "MIC" jack on your recorder or soundcard. The unit may be mounted at a convenient location on the base of the telephone utilizing the adhesive pad.

The beep is powered from a 6VDC plug-in AC Adapter, Part No. 39184, furnished with the unit. Insert the plug on the power cord into the receptacle on the TRP-303. The adapter may be plugged into any adjacent power outlet for 115VAC power.

